

REV	DESCRIPTION	DESIGN	DATE
A0	Release	吴丹平	2016.07.04

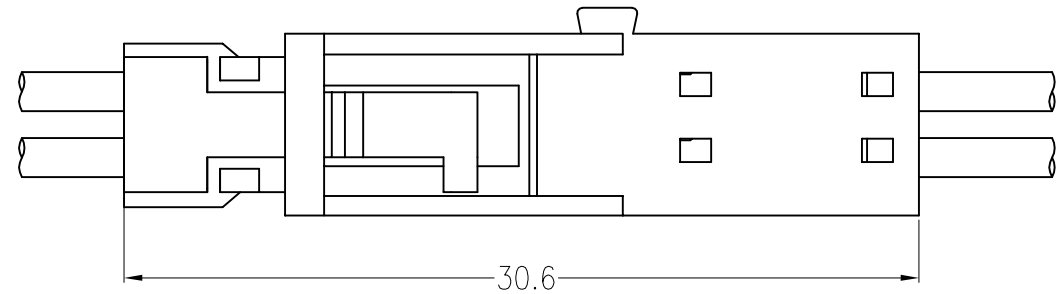

Assembly Layout

主要技术参数 Main Specifications

线 数 (Poles): 02
 接触电阻 (Contact resistance): $\leq 20m\Omega$
 绝缘电阻 (Insulation resistance): $\geq 1000M\Omega$
 额定电压 (Rated voltage): 250V AC DC
 额定电流 (Rated current): 3.0A AC DC
 耐 电压 (Withstand Voltage): 1500V AC/minute
 温度范围 (Temperature Range) : $-25^{\circ}C \sim +85^{\circ}C$

ORDER INFORMATION:

C2542P-02-A6W-P-1			
PART No.	No. OF CIRCUITS:	PACKAGING:	PACKAGING:
	02	1=大口	P=PE
		PLASTIC MATERIAL:	
		A6W=PA66 (WHITE)	

ITEM	COMPONENT	Q'TY	MATERIAL	FINISH
C				
B				
A	PEDESTAL	1 PCS	PA66	

东莞市高迪电子有限公司 DONG GUAN GAO DI ELECTRONICS CO., LTD			TITLE:	
			PART NO.:	
X.±0.5	X.±5'	USE:	C2542P-02-A6W-P-1	
.X±0.3	.X±2'	APPD:		
.XX±0.25	.XX±1'	CHKD:	DWG NO.:	
--	--	DR:	GCCP-0604	
UNITS: mm		蒋建银	SCALE	SHEET
			1 : 1	1 / 1

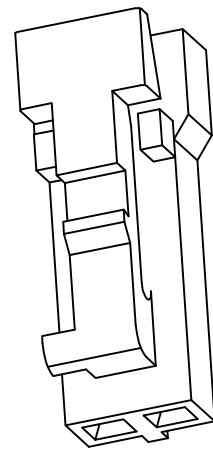
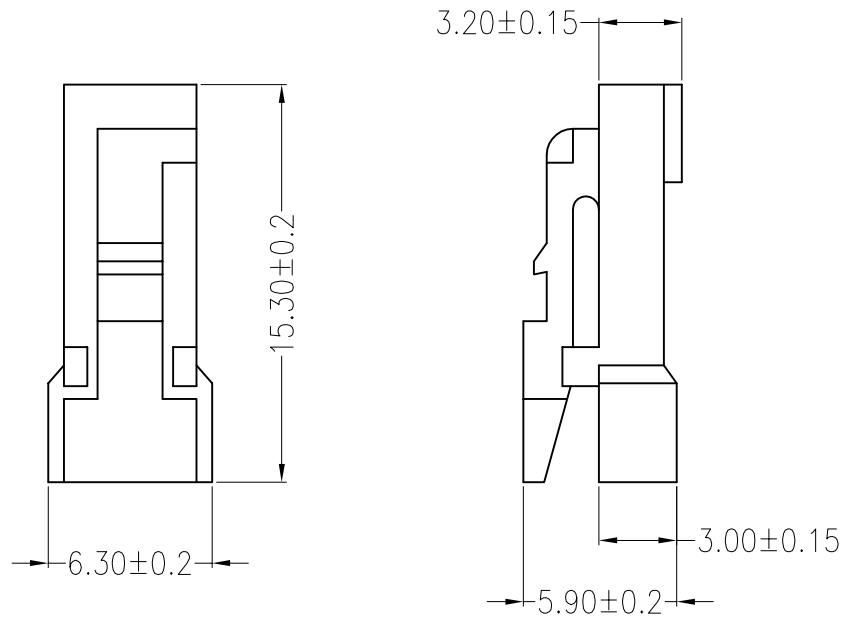

REV	DESCRIPTION	DESIGN	DATE
A0	Release	蒋建银	2017.10.10

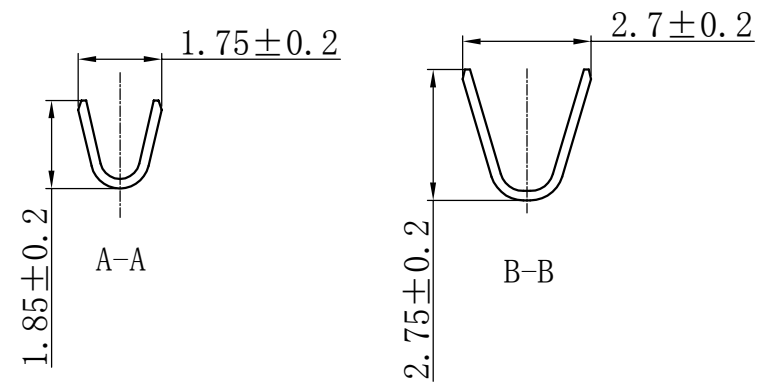
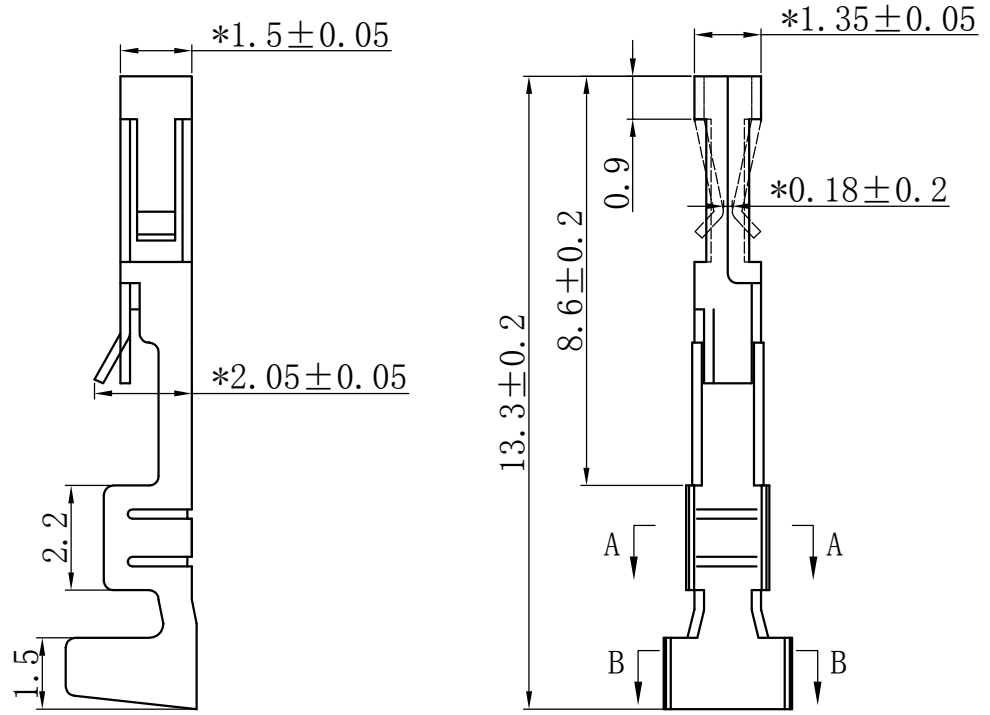

Ordering Information & Specification:

Part No	Wire Range	Insulation O.D.	Material	Finish	Qty/Reel
C2542PT-04端子	AWG #20~#24	2.7mm(max)	Phosphor bronze	Sn-plated	

東莞市高迪電子有限公司 DONG GUAN GAO DI ELECTRONICS CO., LTD			TITLE: 高脚
X±0.5	X±5'	USE: CUSTOMER	PART NO.: C2542PT端子
.X±0.3	.X±2'	APPD: 邵敬和	DWG NO.: GCDZ-0063
.XX±0.25	.XX±1'	CHKD: 田峰	SCALE 1:1
--	--	DR: 蒋建银	SHEET 1/1
UNITS: mm			

REV	DESCRIPTION	DESIGN	DATE
A0	Release	吴丹平	2016.06.15

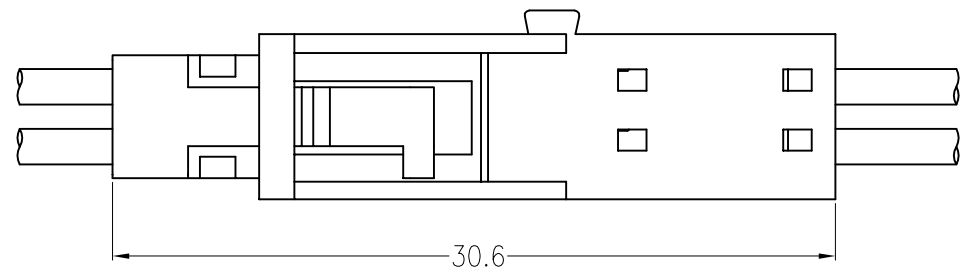
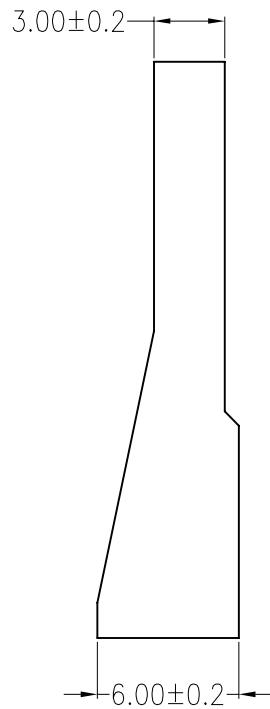
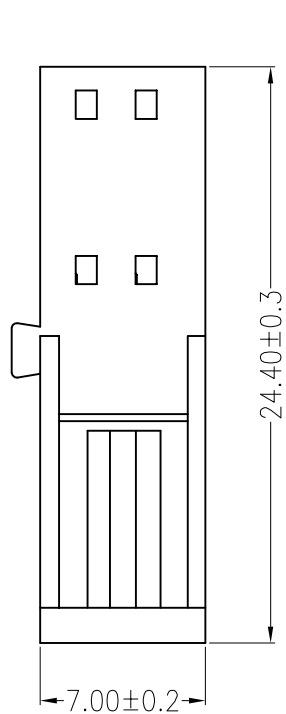

Assembly Layout

主要技术参数 Main Specifications

线 数 (Poles): 02
 接触电阻 (Contact resistance): $\leq 20m\Omega$
 绝缘电阻 (Insulation resistance): $\geq 1000M\Omega$
 额定电压 (Rated voltage): 250V AC DC
 额定电流 (Rated current): 3.0A AC DC
 耐 电 压 (Withstand Voltage): 1500V AC/minute
 温度范围 (Temperature Range): $-25^{\circ}C \sim +85^{\circ}C$

ORDER INFORMATION:

C2542R-02-A6W-P	
PART No. _____	PACKAGING: P=PE
No. OF CIRCUITS: _____	PLASTIC MATERIAL: A6W=PA66 (WHITE)

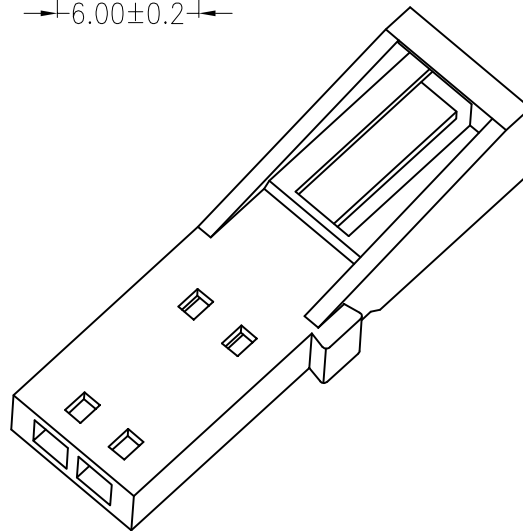
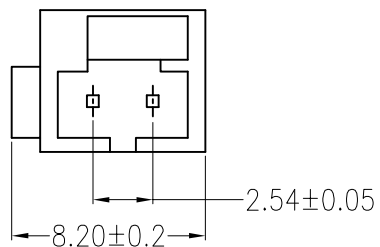

ITEM	COMPONENT	Q'TY	MATERIAL	FINISH
C				
B				
A	PEDESTAL	1 PCS	PA66	

东莞市高迪电子有限公司 DONG GUAN GAO DI ELECTRONICS CO., LTD			TITLE:	
X.±0.5	X.±5'	USE:	PART NO.:	
.X±0.3	.X±2'	CUSTOMEP	C2542R-02-A6W-P	
.XX±0.25	.XX±1'	APPD: 邵敬和	DWG NO.:	
--	--	CHKD: 田峰	GCCP-0603	
⊕	UNITS: mm	DR: 蒋建银	SCALE	SHEET
			1 : 1	1 / 1

A B C D E F

REV	DESCRIPTION	DESIGN	DATE
A0	Release	蒋建银	2017.10.10

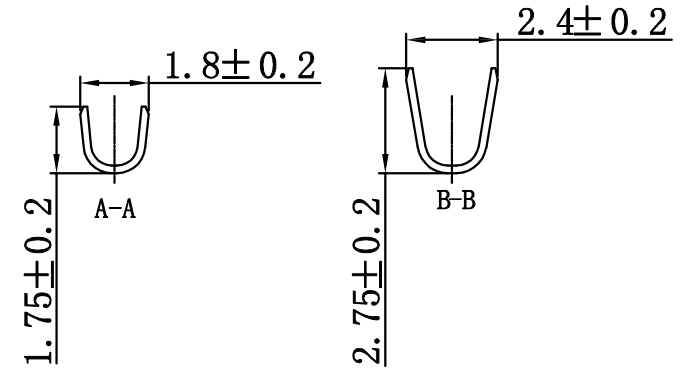
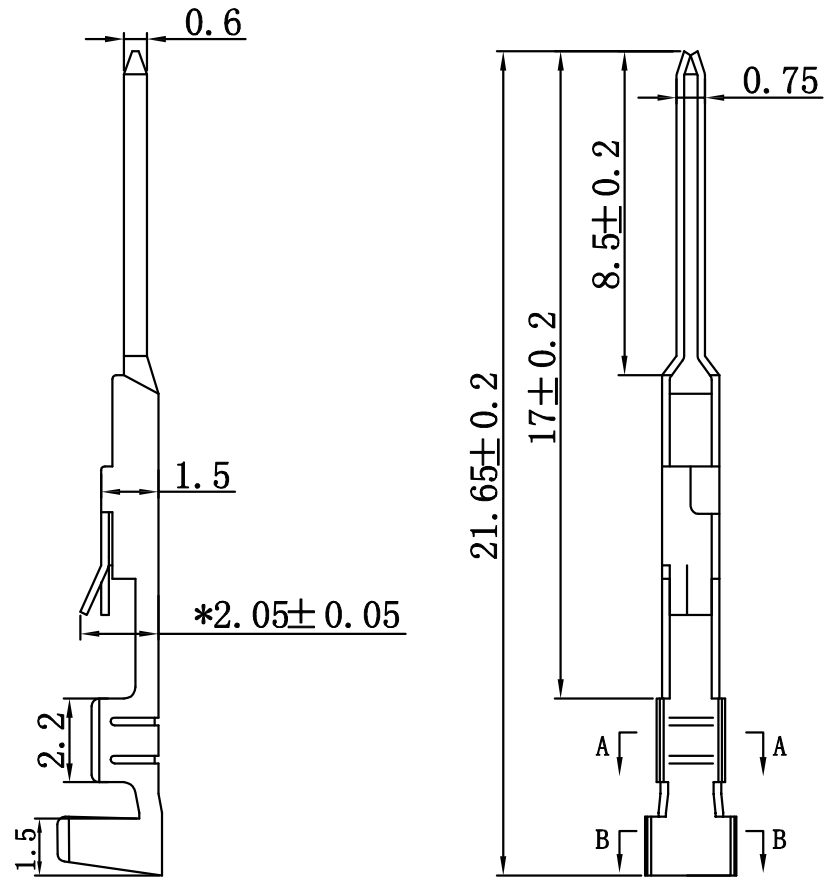

Ordering Information & Specification:

Part No	Wire Range	Insulation O.D.	Material	Finish	Qty/Reel
C2542RT-04端子	AWG #20~#24	2.7mm(max)	Phosphor bronze	Sn-plated	

東莞市高迪電子有限公司 DONG GUAN GAO DI ELECTRONICS CO., LTD			TITLE: 高脚	
X.±0.5	X.±5'	USE: CUSTOMER	PART NO.: C2542RT端子	
.X±0.3	.X±2'	APPD: 邵敬和	DWG NO.: GCDZ-0081	
.XX±0.25	.XX±1'	CHKD: 田峰	SCALE 1:1	
--	--	DR: 蒋建银	SHEET 1/1	
UNITS: mm				

A B C D E F

A

B

C

D

E

F

REV	DESCRIPTION	DESIGN	DATE
A0	Release	吴丹平	2016.06.15

1

1

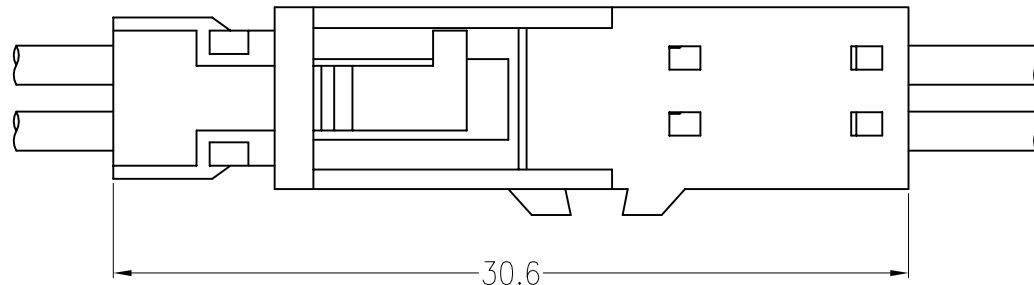
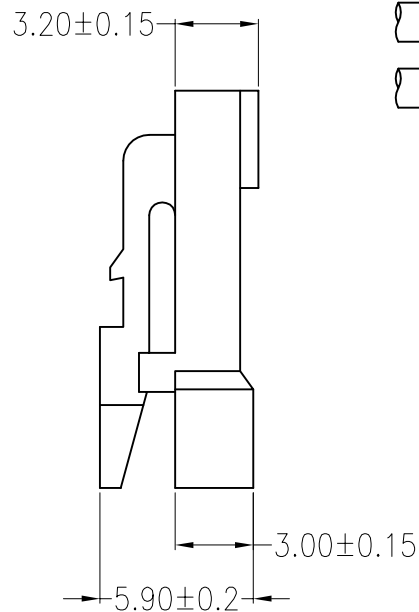
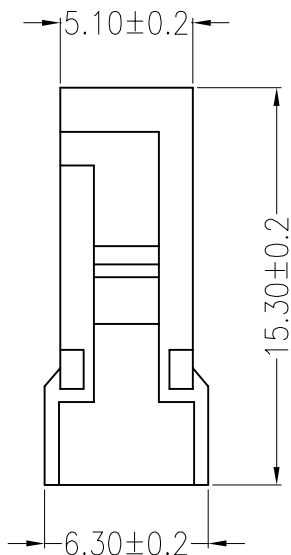

Assembly Layout

主要技术参数 Main Specifications

线 数 (Poles): 02
 接触电阻 (Contact resistance): $\leq 20m\Omega$
 绝缘电阻 (Insulation resistance): $\geq 1000M\Omega$
 额定电压 (Rated voltage): 250V AC DC
 额定电流 (Rated current): 3.0A AC DC
 耐 电压 (Withstand Voltage): 1500V AC/minute
 温度范围 (Temperature Range) : $-25^{\circ}C \sim +85^{\circ}C$

ORDER INFORMATION:

C2543P-02-A6K-P-1			
PART No.		PACKAGING:	1=大口
No. OF CIRCUITS:	02	PACKAGING:	P=PE
		PLASTIC MATERIAL:	A6K=PA66 (BLACK)

3

3

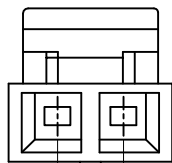

2.54±0.05

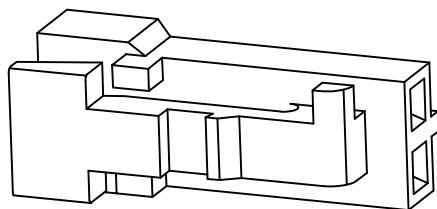

4

4

C				
B				
A	PEDESTAL	1 PCS	PA66	
ITEM	COMPONENT	Q'TY	MATERIAL	FINISH

东莞市高迪电子有限公司
 DONG GUAN GAO DI ELECTRONICS CO., LTD

TITLE:

X.±0.5 X.±5'

USE:
CUSTOME P

PART NO.:

.X±0.3 .X±2'

APPD:
邵敬和

C2543P-02-A6K-P-1

.XX±0.25 .XX±1'

CHKD:
田 峰DWG NO.:
JKUN/GCCP-0606

-- --

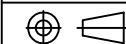
DR:
蒋建银SCALE
1 : 1 SHEET
1 / 1UNITS:
mm

5

A

B

C

D

E

F